

# Smart transformation of a remote province into innovative region / Aviation Valley case

Marek Darecki

March, 2015

# Podkarpackie Province



High-tech industry



Nature



Rzeszów, city of innovation



International airport

# Transformation of Polish Aerospace Industry

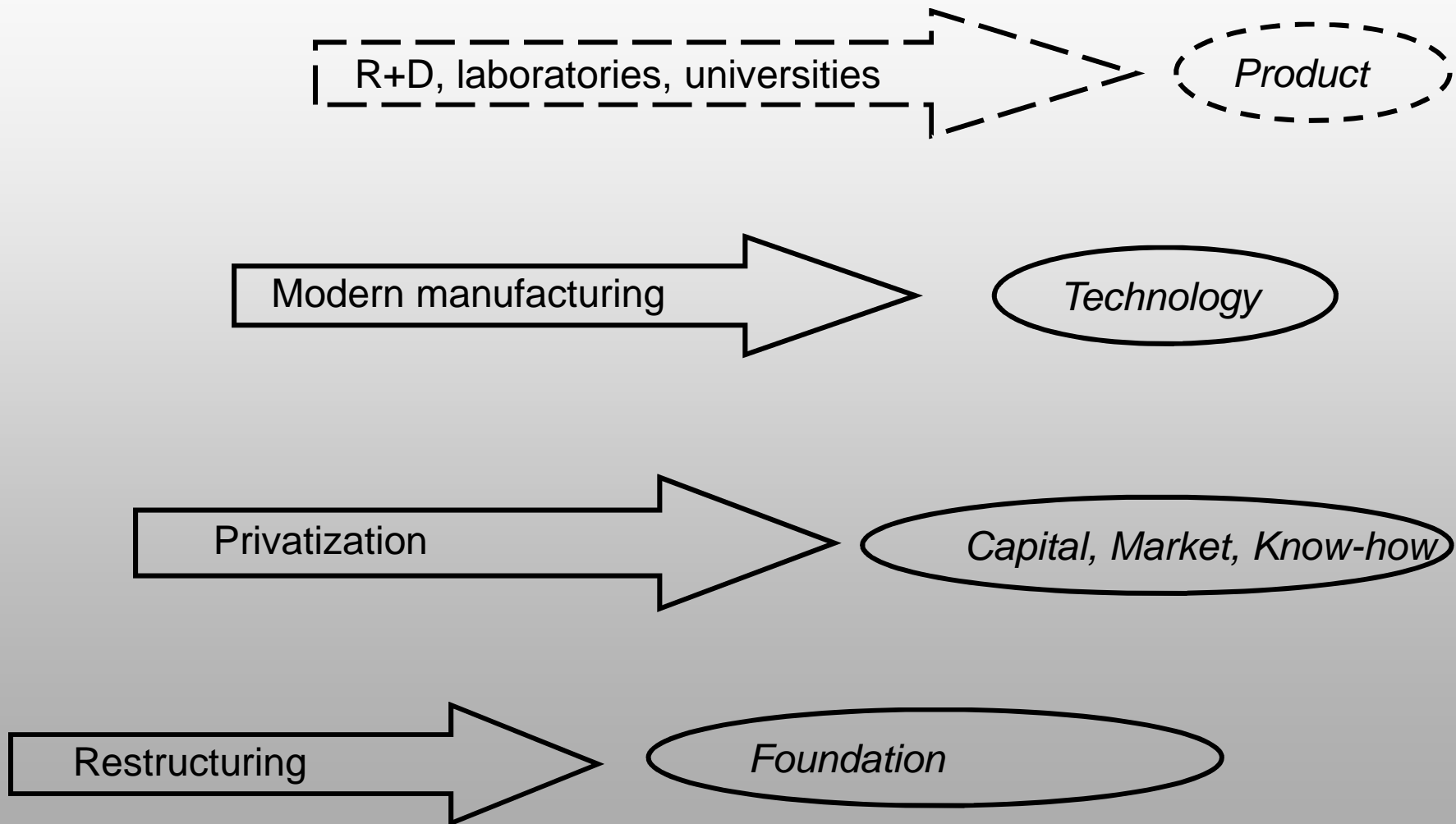

# Beginning of „big change” in Poland

1980



Lech Walesa in shipyard



Lech Walesa in WSK

1989



Round table dialogue

„Solidarity”, 1980

Martial law, 1981

Round Table agreement, 1989

New Government

Plan of reform / shock therapy

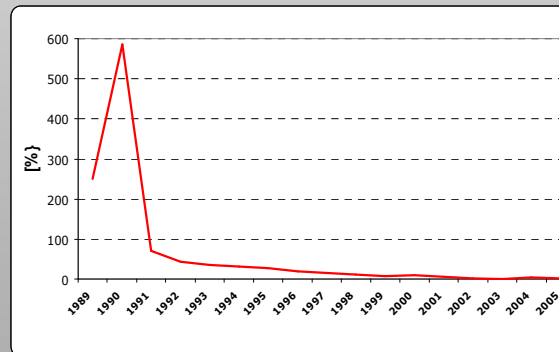

Inflation



Leszek Balcerowicz



# WSK before big change

Stable, legacy product,  
monoculture

One dominating client, Soviet  
Union, 80% of sales

Centralized structure

Lack of knowledge about  
modern business

Dependence on the Warsaw  
„head office”

11 000 employees



# Dramatic change in WSK

Loss of 80% of volume

Cash flow issue

No work for employees

Breaking cooperation ties

No support from the  
„head office”



# Actions

New Management / determination

## Restructuring plan

lay offs, 5000 people

sale of redundant assets

marketing activity, new 80 customers

mentality change

Support of Trade Unions

# WSK acquisition by UTC, March 2002

UTC acquires 85% shares for \$70M

## Government guarantees

Investment \$70M

Employment guarantee 2 Y

## Social Package signed with Unions

Employment guarantee 2Y + 4Y

Privatization bonus 11K PLN

Salary increase to 120% of average in Poland





# Aviation Valley



	2003	2014
Members	18	120
Employment	9 000	23 000
Sales	0,2 mld	\$ 2 mld \$



FDGS  
PWRzeszow

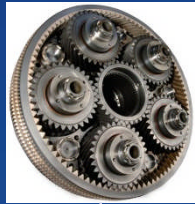

Blades  
Avio Polska

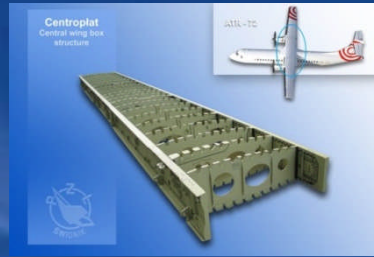

Wing structure  
PZL Świdnik Agusta Westland



APU  
PWAP  
Rzeszow

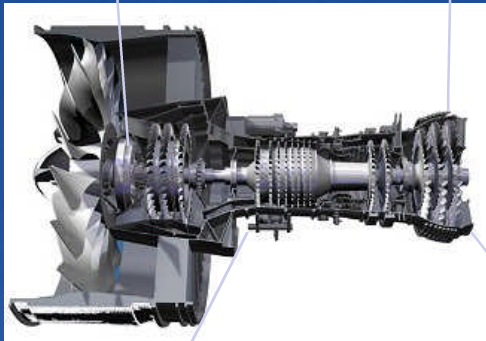

Landing gears  
Goodrich  
Polska

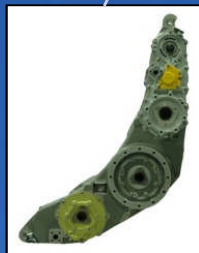

Gear boxes  
Hispano Suiza  
Polska



Turbine  
modules  
MTU Polska



F 100 engines assembled at PW Rzeszow  
Landing gears Goodrich Polska

# Products

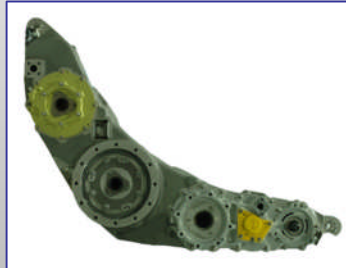
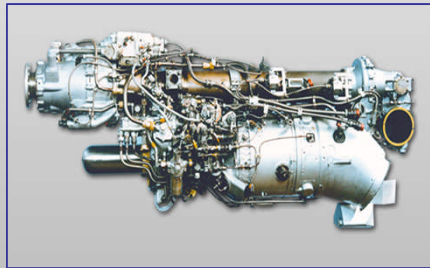



OEM's	SME's	Equipment, tooling, material, special processes	Consulting Business support	Development agencies Technology Parks	R&D Engineering Education Training
-------	-------	---	-----------------------------	---------------------------------------	------------------------------------

# Future skills / education



Universities



High school work shops

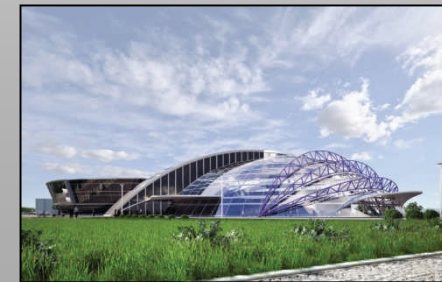

„Tech University for children”



# Special Economic Zone



# Supply chain

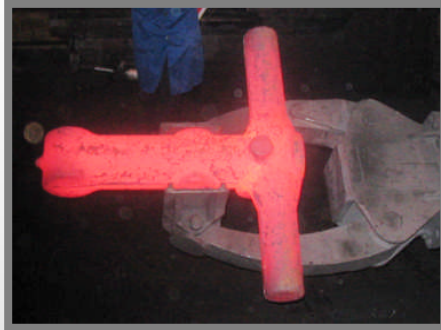

Forging, ZKM Stalowa Wola



Bushings , Ultratech



Landing gears, Goodrich Krosno



Polish F-16, engines assembled at WSK Rzeszów, landing gears made by Goodrich Krosno



# Strategy of Aviation Valley

New production programs

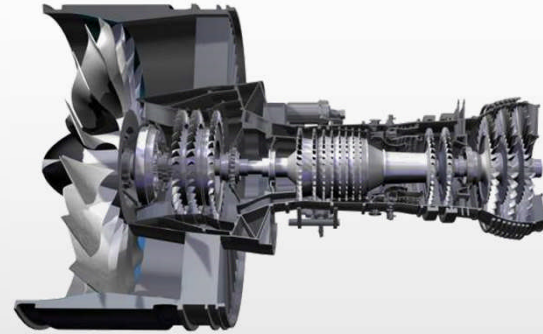

New investors and SMEs



Research and Development



# Nature











Sustainable  
tourism

Active tourism  
Village tourism  
Religion tourism  
Business tourism  
Heritage tourism  
Recreation

Health

Medical clinics  
Health recovery  
Leisure, wellness  
SPA  
Older people care  
Organic food

Eco  
technology

Green technology  
Green energy  
Eco-buildings  
Technology for  
tourism  
Recycling

# Strategy Europe 2020

Smart growth

Economy based on knowledge and innovation

Sustainable growth

More resource efficient, greener and more competitive economy

Inclusive growth

High-employment economy delivering economic, social and territorial cohesion

## Strategy Podkarpacie 2020 / „smart specialisations”



ICT / Informatyka Podkarpacka

**KLASTERit**

# „Green hills of Podkarpacie”, leading project





# Getting ready



Training project  
Modern tourism

Social project  
Mentality change

# Working together / synergies

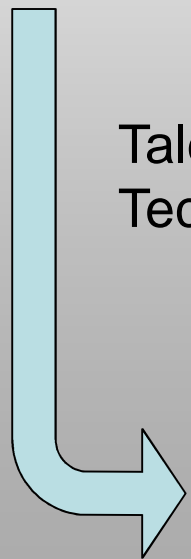

Talents  
Technology

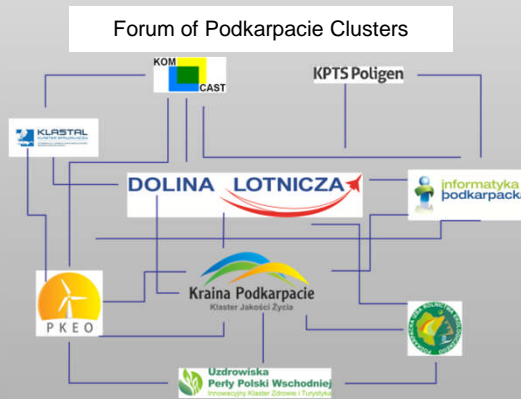

Integrated  
solutions

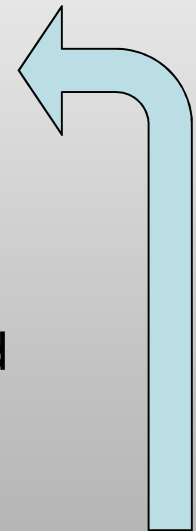

Green  
energy

Intelligent  
buildings

Sustainable  
tourism