



Innovation & Competitiveness, Sustainability and Environment

Drama, Greece - May 2015



Just Some National Trends



We export to more than 116 countries



We Rank 7th on Natural Stone Internacional Trade



2nd Country Per Capita – Natural Stone Internacional Trade



We cover our imports in 823%



Nationally represents a total of 1.4 Billion €



3355 Companies
27000 Workers



We export 45% outside Europe



In terms of Added Value just telecommunications are raking over Natural Stone



In some regions of the country, the Natural Stone Sector is the most important employer

What makes our Sector Sustainable?

EVERITHING!



CEVALOR®

Technological Center for the Portuguese Natural Stone

Research

Technological Transfer

Technical and Technological Support

Human Resources

Sector Dissemination



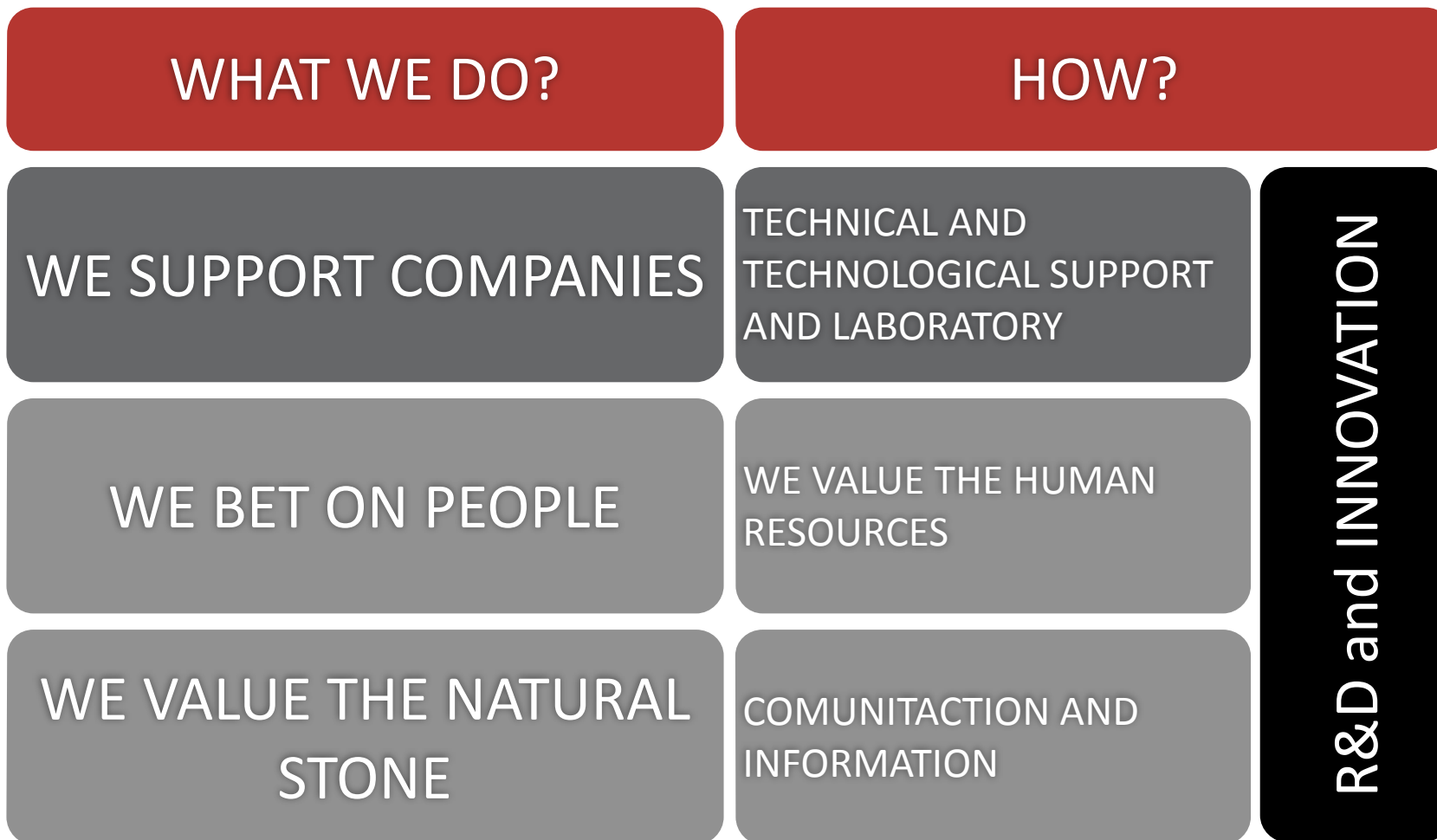

How Can We lead to Innovation & Competitiveness?

Excellence in Raw Material

Limestone









Marble

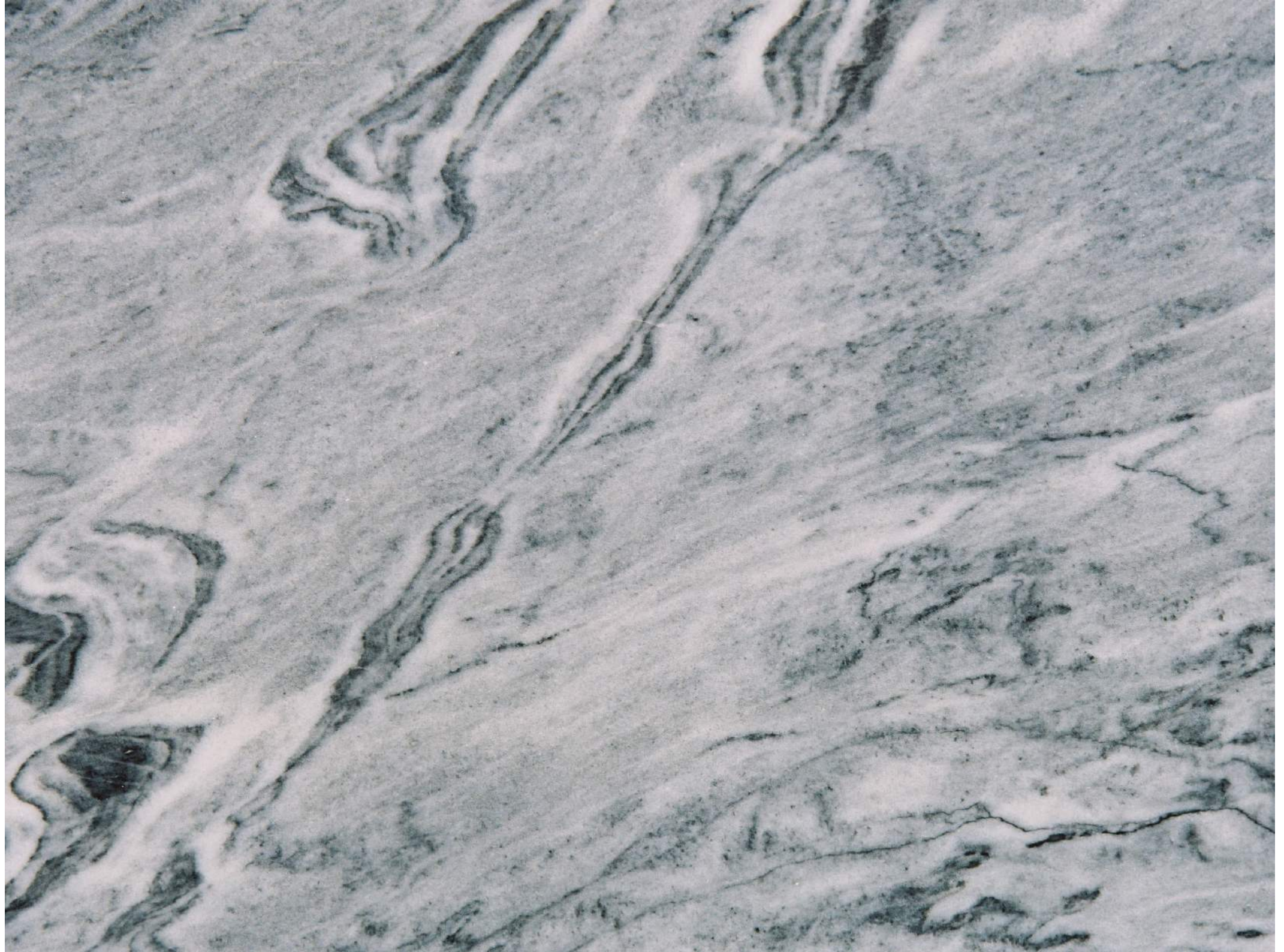



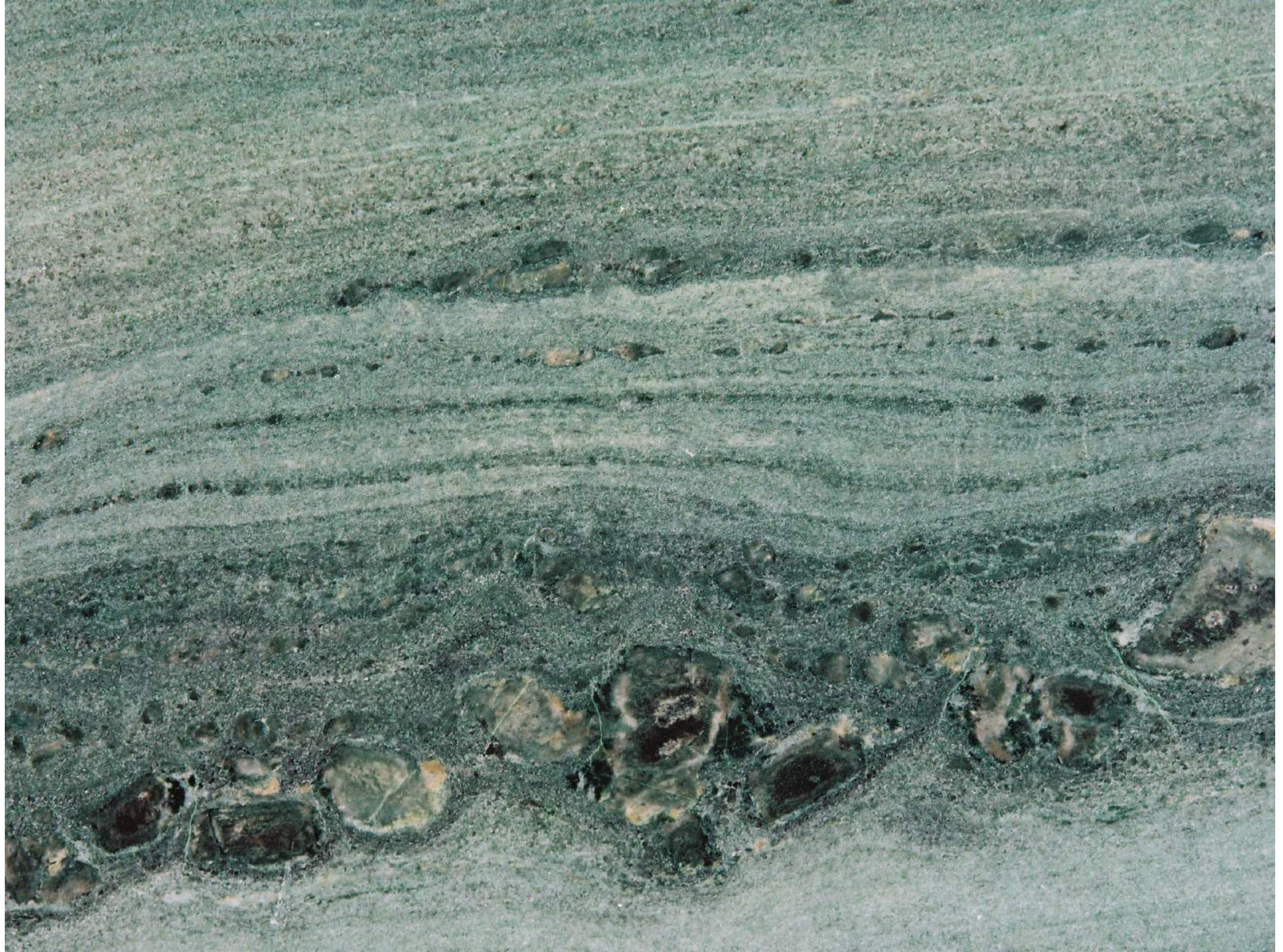

Granite



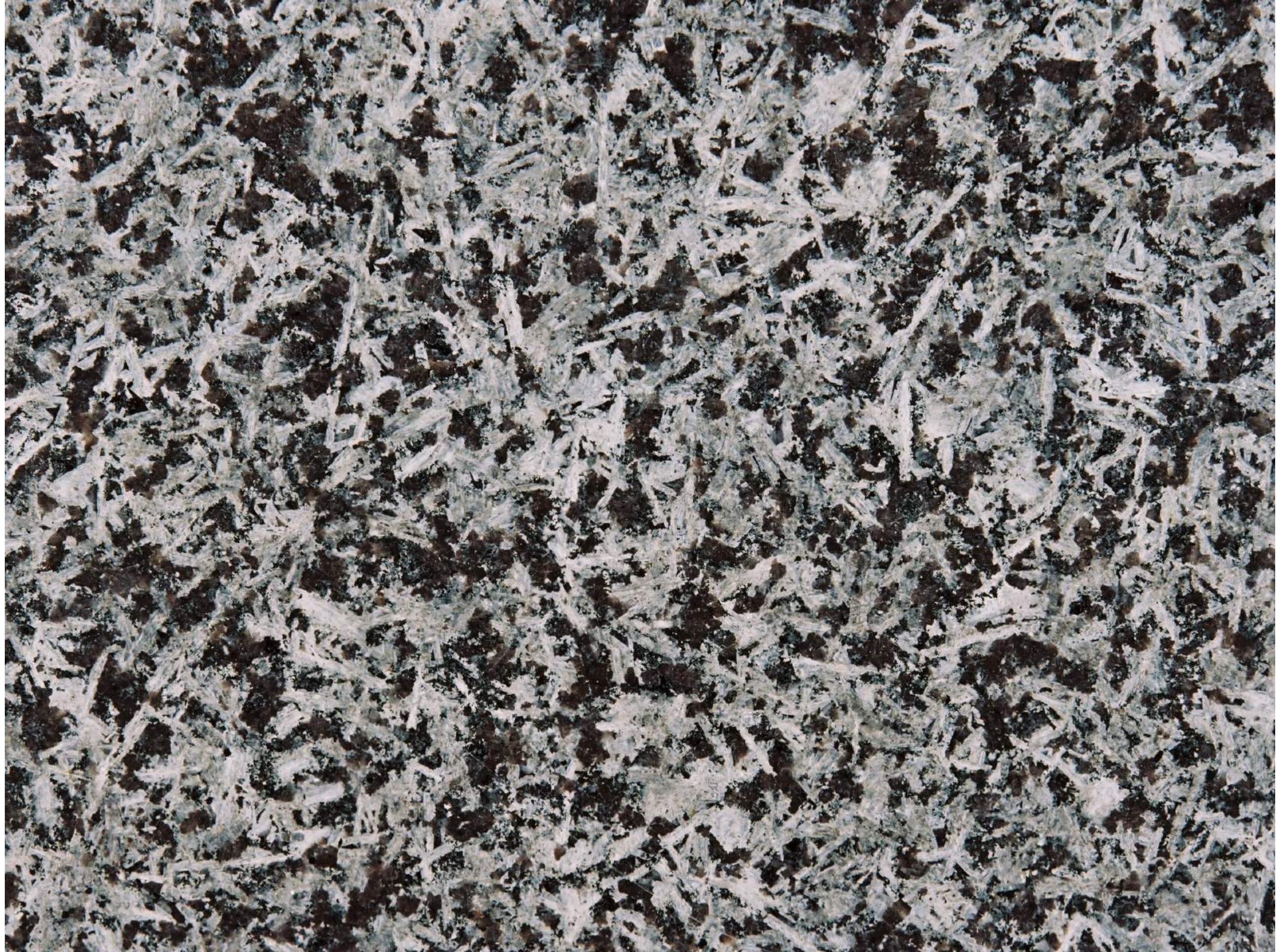





Schist





How Can We lead to Innovation & Competitiveness?

Raw Material Accessibility

Geological Survey, Characterization Territory Planning

Just Some Facts

- More than 70 Varieties of Marble, Limestone, Granite and Schist;
- Marble with exploitation potential was found up to > 300 meters deep;
- We have exploitable Marble for more 550 Years!;
- More than 250 Active Quarries;
- One of the deepest Quarry in Europe (180 m);
- Thematic Mapping - First European Region with a Complete Geological vs Environmental Mapping;
- More than 4.000 ha prospected;
- More than 3.000 m of surveys.





Concelho de Porto de Mós

Concelho de Santarém





How Can We lead to Innovation & Competitiveness? Landscape Planning & Restoration



How Can We lead to Innovation & Competitiveness? Ecology, Biodiversity and Environment

Environmental Sensitivity

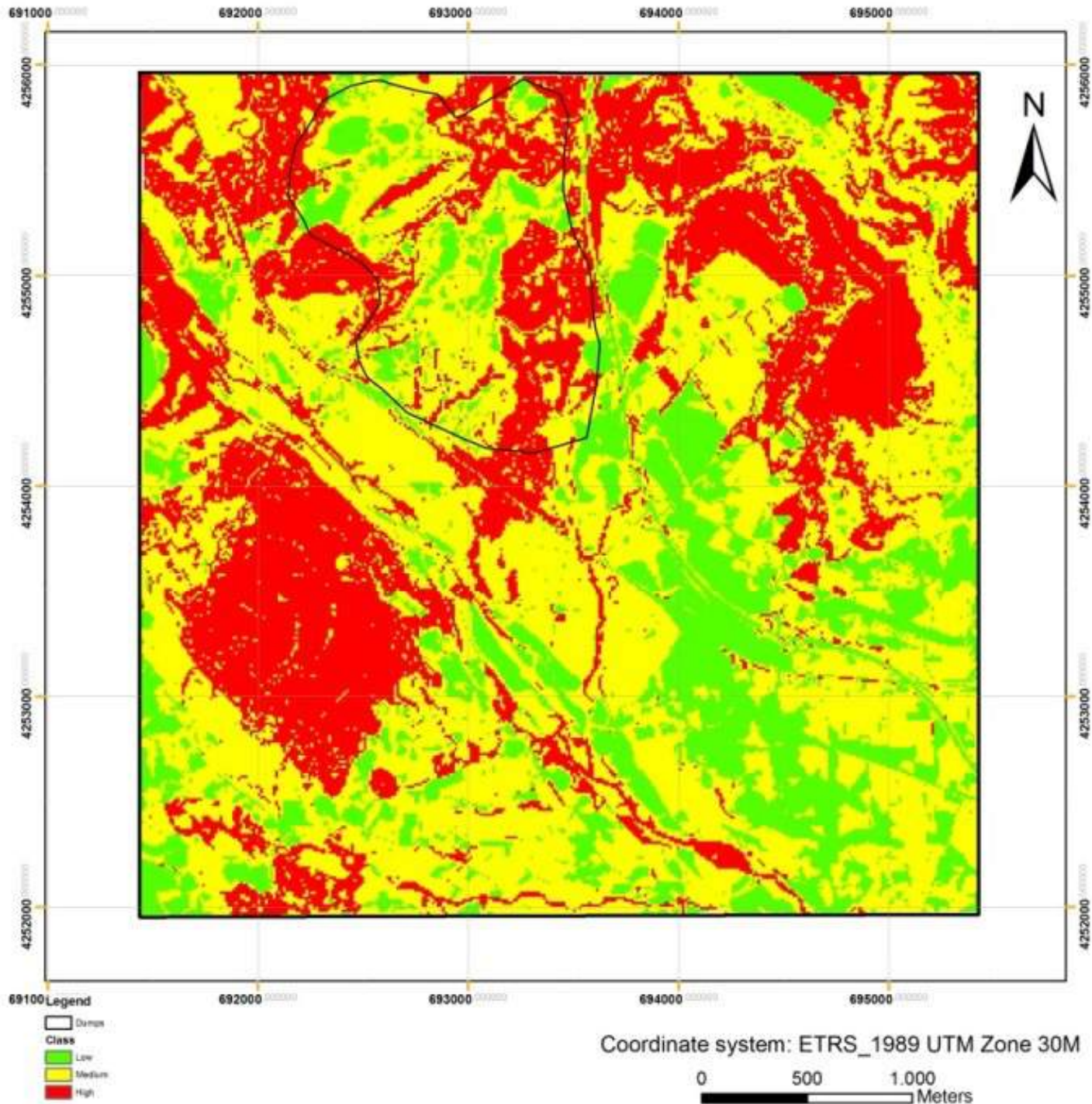

Drama, Greece
May 2015

How Can We lead to Innovation & Competitiveness? Waste Management





How Can We lead to Innovation & Competitiveness? Water Management







How Can We lead to Innovation & Competitiveness? Human Resources

Human Resources & Training

Just Some Numbers



Over 560 Different
Training Courses



Over 3.200
Beneficiaries (SME's)



Over 16.800 Trainees



Over 160.000 Training
Hours



Our Goals

APN Natural Stone
Academy

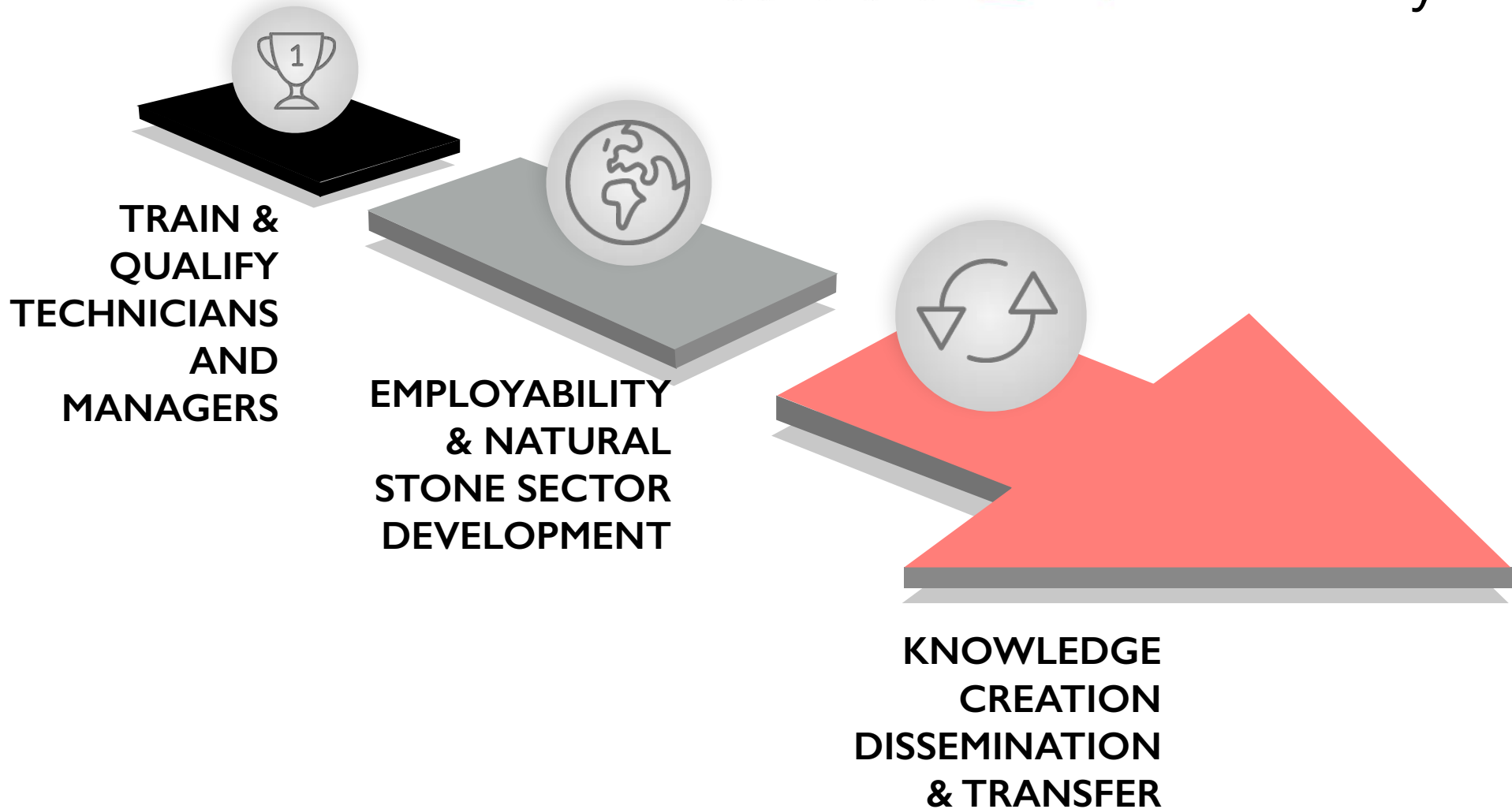

ATENÇÃO PERIGO

EXPLORAÇÃO DE PEDREIRA





How Can We lead to Innovation & Competitiveness?

Quality

Characterization, Standardization &
Brand

53

TRONIC

ARMSTRONG
1.7.2008
1.7.2008



1 - 12/07 - 1

4 - 11/07 - 4

7 - 11/07 - 7

5 - 11/07 - 5

0

1 - 21/07 - 1

0911



EXIJA ESTE SELO
PEDRA MADE IN PORTUGAL

WWW.STONE-PT.COM



valorpedra

Assimagra

COMPETE

OR

100

How Can We lead to Innovation & Competitiveness?

Strategy

PORTUGAL
PEDRA A PEDRA
Área de Marketing e Comunicação
Pedra Natural Portuguesa



How Can We lead to Innovation & Competitiveness?

Technology

The Lean Concept

The Wright Material

At the Wright Moment

In the Wright Conditions

In the Wright Place



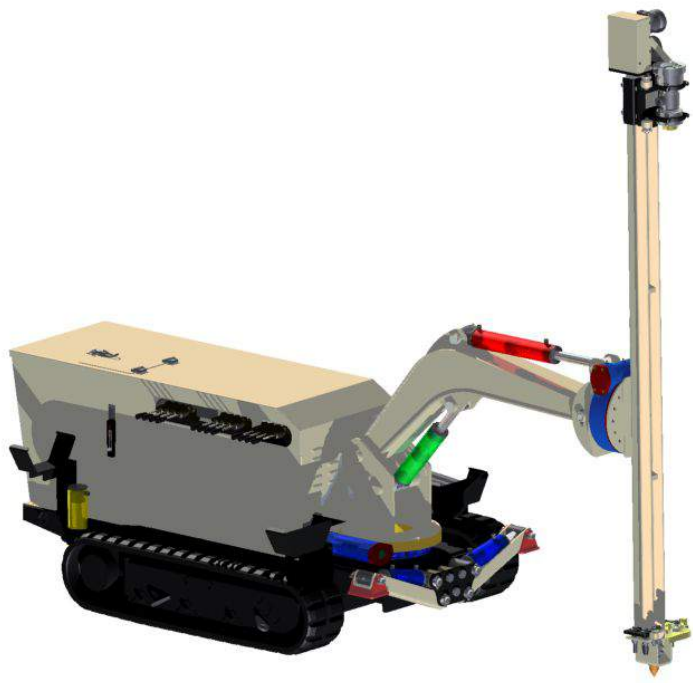

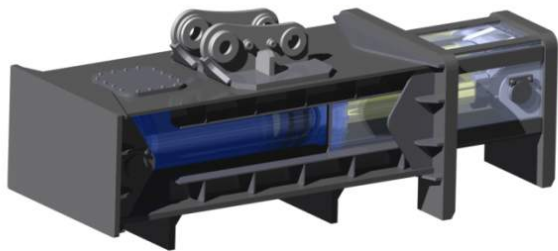

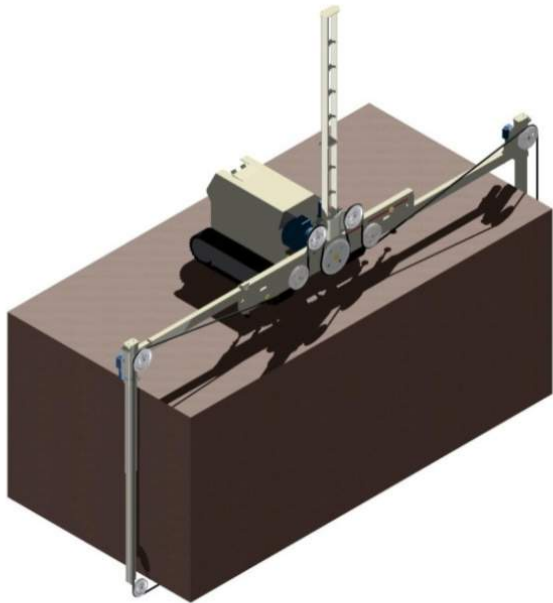

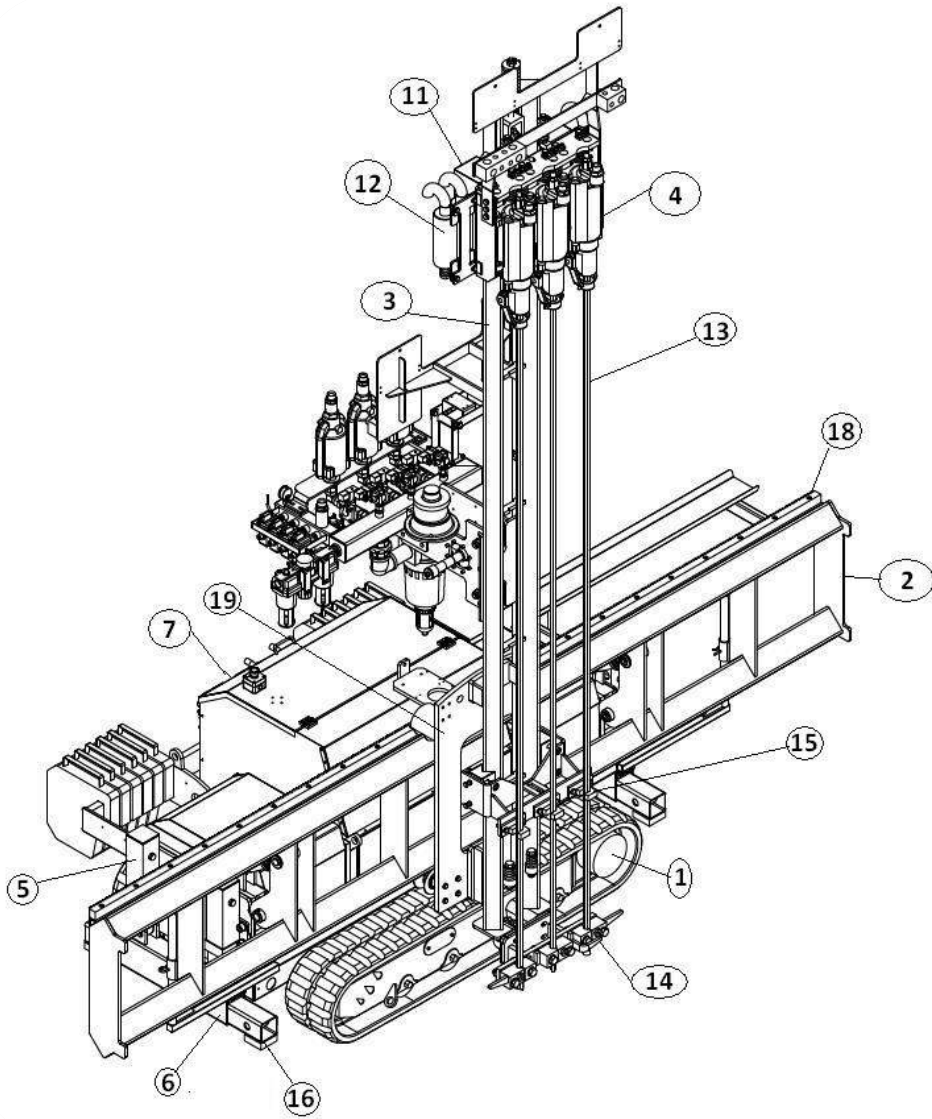



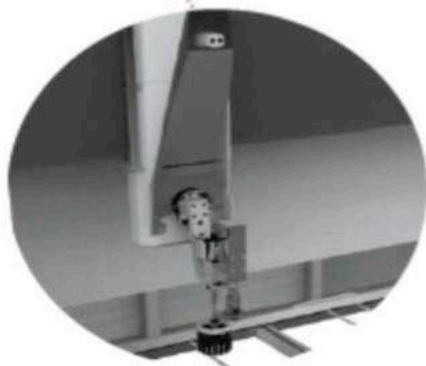
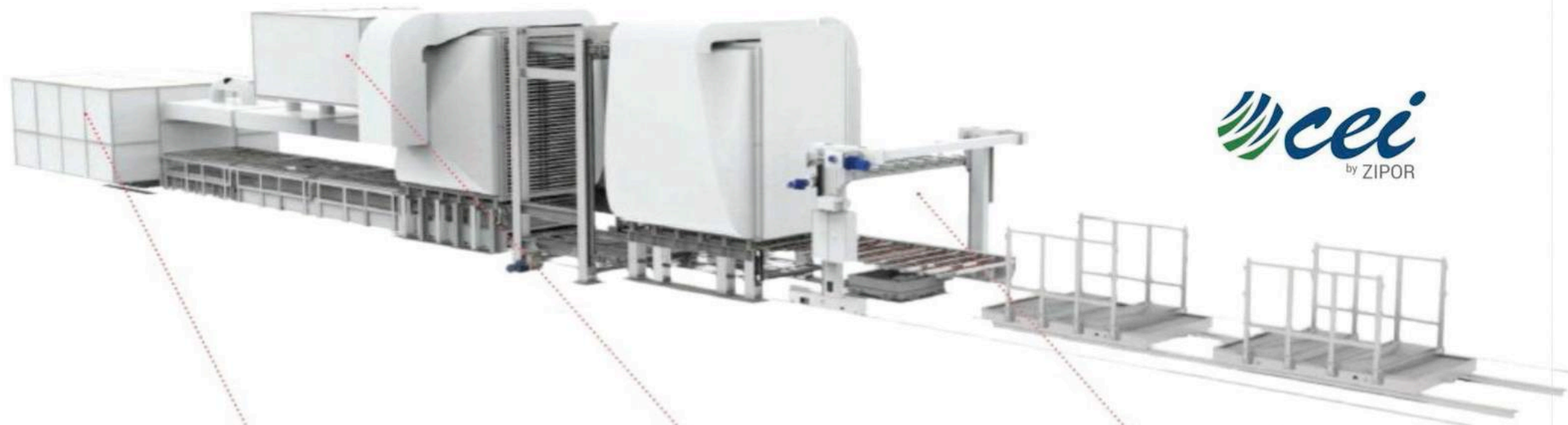

*Aplicação automática
de resina*

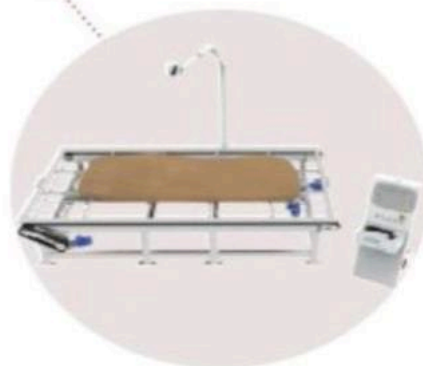

Digitalização de chapa



Etiquetagem das chapas



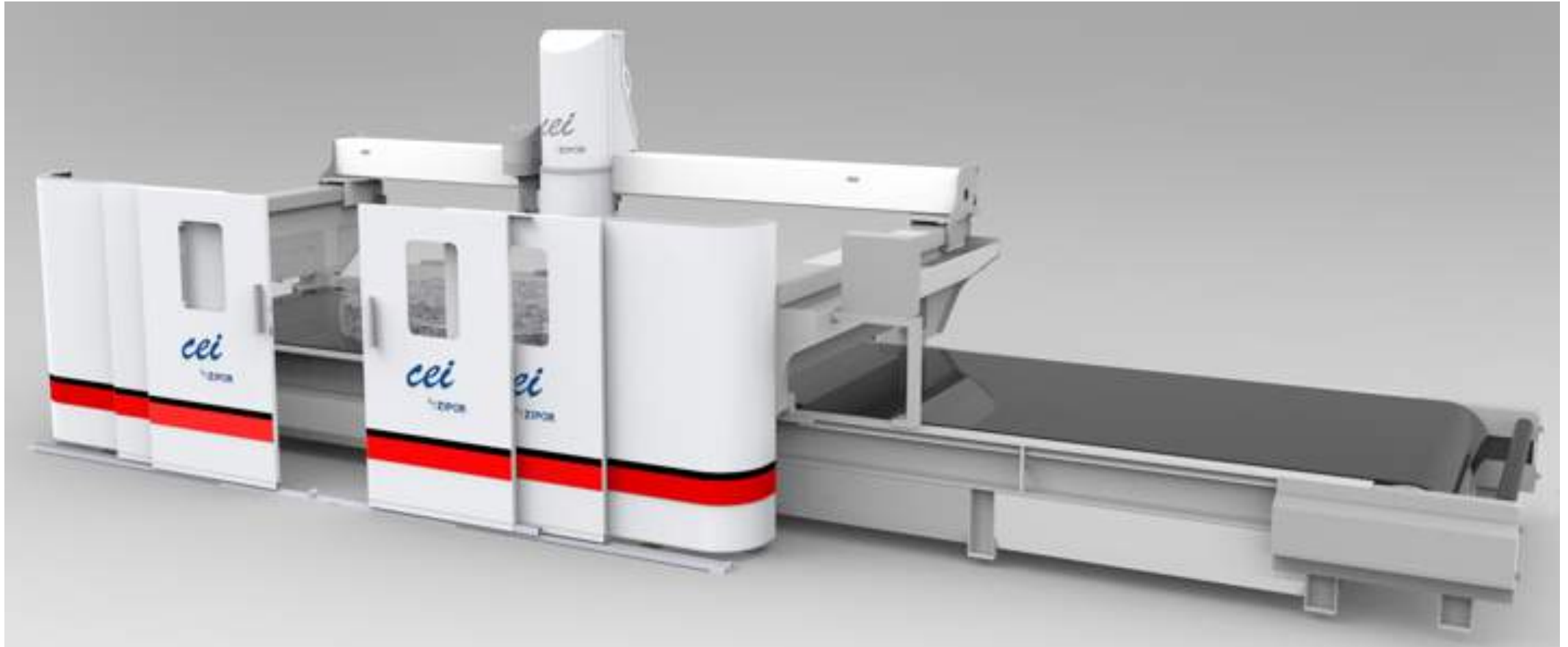



How Can We lead to Innovation & Competitiveness? New Products/Design















How Can We lead to Innovation & Competitiveness?

Turism



ROTA DO PATRIMÓNIO INDUSTRIAL

TONSDEMÁRMORE

MARBLE TONES ROUTE









Q & A



Thank You!

nelson.cristo@cevalor.pt

+351 965 239 893

Drama, Greece
May 2015

